

Features

- Intel® Processor N-series
- Onboard LPDDR5 Memory, up to 8GB
- Onboard eMMC Storage, up to 64GB
- 1Gigabit LAN x 1
- HDMI 1.4b x 1
- USB 3.2 Gen 2 (Type-A) x 3, 10-pin USB 2.0 x 2/UART x 1
- 40-pin GPIO x 1
- 12V DC-in, 5A
- TPM 2.0



Specifications

System	
Processor	Intel® Core™ 3 Processor N355 Intel® Processor N250 Intel® Processor N150 (formerly Twin Lake)
Graphics	Intel® UHD Graphics
Memory	Dual-Channel LPDDR5, up to 8GB
Storage	Up to 64GB eMMC
I/O	HDMI 1.4b/USB 3.2 Gen 2 STACK Connector x 1 (Type-A) 4-pin Front Panel x 1 2-pin Fan Wafer x 1 (12V) 2-pin RTC Battery Wafer x 1
Camera	—
USB	USB 3.2 Gen 2 (Type-A) x 3 10-pin USB 2.0 x 2/UART x 1
Expansion	40-pin GPIO x 1
Display Interface	HDMI 1.4b x 1
Ethernet	1GbE RJ-45 x 1 (Realtek RTL8111H CG)
Security	Onboard TPM 2.0
RTC	Yes
OS Support	Windows® 10 Enterprise LTSC 2021 Linux: Ubuntu 22.04 LTS/Kernel 5.15, Yocto 4.0
Power Requirement	
Power	12V DC-in, 5A
Power Supply Type	AT (default) /ATX
Power Consumption (Typical)	30~36W
Mechanical	
Dimension	3.34" x 2.20" (85mm x 56mm)
Net Weight	0.33 lb. (0.15Kg)
Gross Weight	0.44 lb. (0.20Kg)
Environment	
Operating Temperature	32°F ~ 140°F (0°C ~ 60°C) / 0.5 airflow, WITAS1 -4°F ~ 158°F (-20°C ~ 70°C) with active cooler
Operation Humidity	0% ~ 90% relative humidity, non-condensing
MTBF	685,218 Hours
Certification	CE/FCC Class A, RoHS Compliant, REACH

Packing List

- UP TWL with Passive Heatsink

Block Diagram

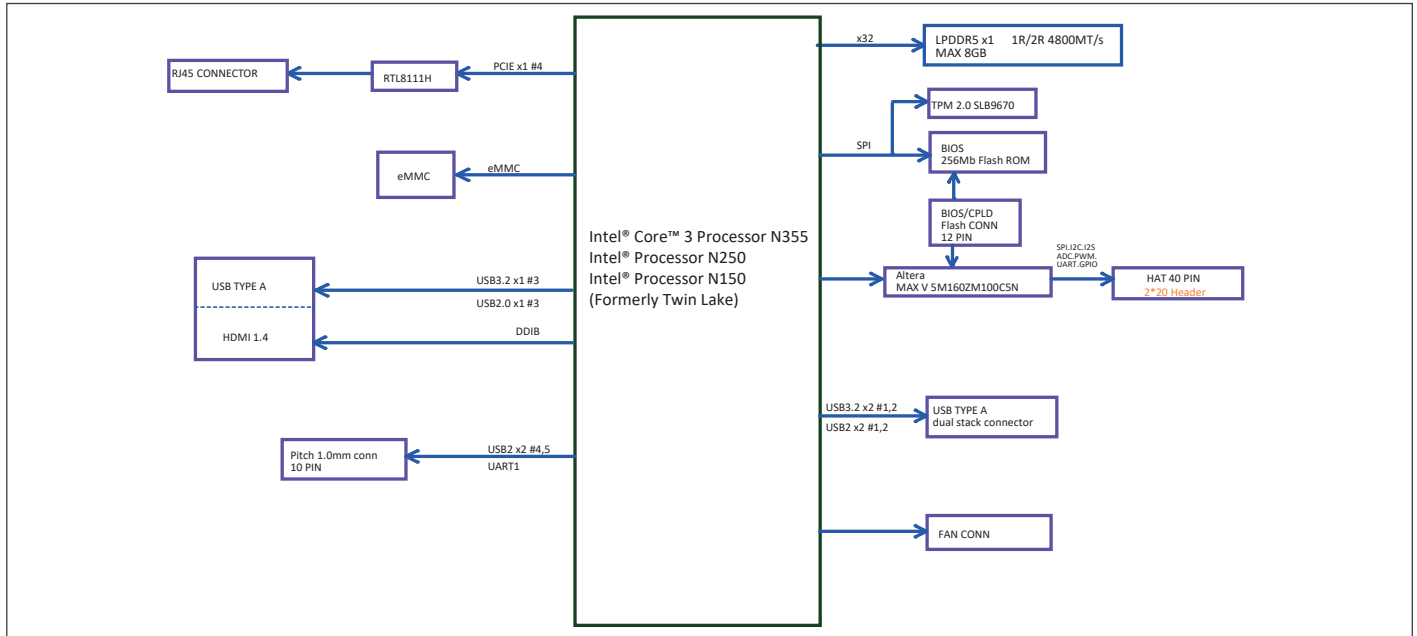

Dimension

Unit: mm

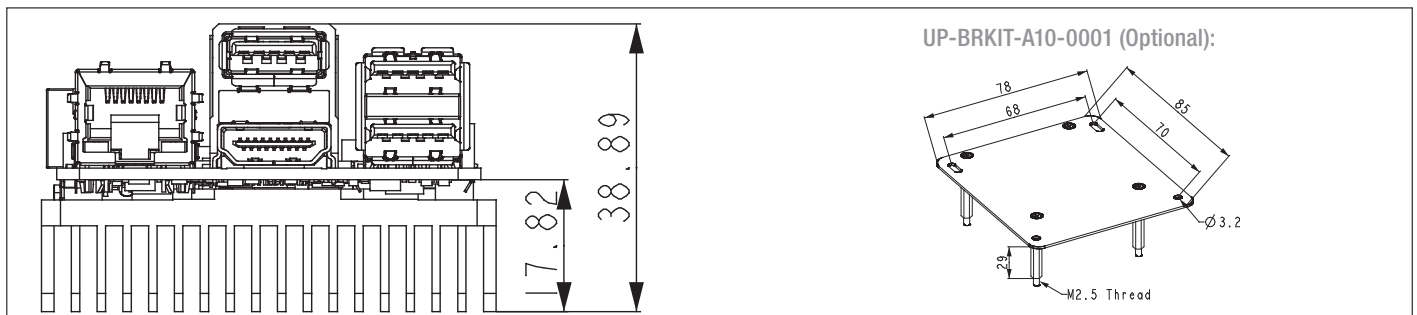

UP-BRKIT-A10-0001 (Optional):

Ordering Information

Part Number	CPU	Core	TDP	Memory	Storage	Thermal Solution
UP-TWLN150-A10-0864	Intel® Processor N150	4	6W	8GB	64GB	Passive Heatsink
UP-TWLN150-A12-0864	Intel® Processor N150	4	6W	8GB	64GB	Active Cooler

Optional Accessories

Part Number	Description
125530060L	Power Adapter (TF)PowerAdapter.DC.100/240V.12V.5A.60W.Powertron.PS1065-120IB500.
UP-ADLN01-COOLER-A01	UP-ADLN01.heatsink w/cooler.A1.0